

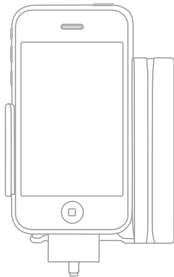

# **Swipe It User's Guide**

## **Secure Credit Card Terminal**

for iPhone and iPod touch



**[www.macally.com](http://www.macally.com)**

## Introduction

Thank you for purchasing the Macally Swipe It Reader, the most secure mobile credit card terminal with an encrypted reader head.

Before you begin using the Macally Swipe It Reader, be sure to read this user's guide in its entirety. Please note, your iPhone or iPod touch must have an Internet connection in order to process the credit card.

## Package Contents

- Swipe It Reader
- USB AC Adaptor
- Mini-USB Cable
- User's Guide
- Wristlet

## Compatibility

- iPhone 3GS
- iPhone 3G
- iPhone
- iPod touch 2nd Generation
- iPod touch 1st Generation
- iPhone OS 3.0 and above

Supports the below credit card brands:

- Visa, MasterCard, American Express, and Discover

# Macally Product Information

## Registration

Please register this product at [www.macally.com/register.html](http://www.macally.com/register.html).

## Technical Support

For hardware question about the Swipe It Reader, please E-mail us at [techsupport@macally.com](mailto:techsupport@macally.com), In U.S.A. please call 1-909-230-6778  
Mon-Fri 8:30 AM - 5:30 PM, Pacific Standard Time

For support of the Swipe It App, Gateway set up, merchant account and credit card processing, please send an email to [support@simplyswipeit.com](mailto:support@simplyswipeit.com) or visit [www.simplyswipeit.com](http://www.simplyswipeit.com)

## Warranty

Macally peripherals warrants that this product will be free from defects in title, materials and manufacturing workmanship for one year from the date of purchase. If the product is found to be defective then, as your sole remedy and as the manufacturer's only obligation, Macally will repair or replace the product. This warranty shall not apply to products that have been subject to abuse, misuse, abnormal electrical or environmental conditions, or any condition other than what can be considered as normal use.

## Limitation of Liability

The liability of Macally Peripherals arising from this warranty and sale shall be limited to a refund of the purchase price. In no event shall Macally Peripherals be liable for costs of procurement of substitute products or services, or for any lost profit, or for any consequential, incidental, direct or indirect damages, however caused and on any theory of liability, arising from this warranty and sale. These limitations shall apply not with standing any failure of essential purpose of any limited remedy.

Copyright® 2010 by Macally Peripherals

## Hardware Basics

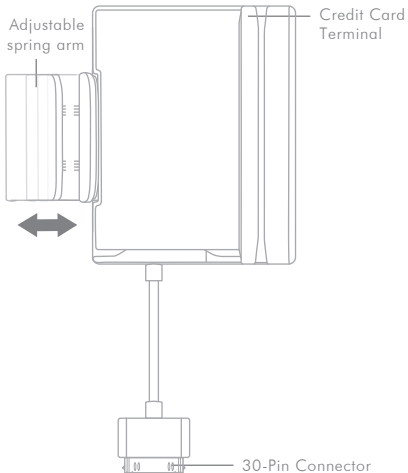

## Hardware Basics

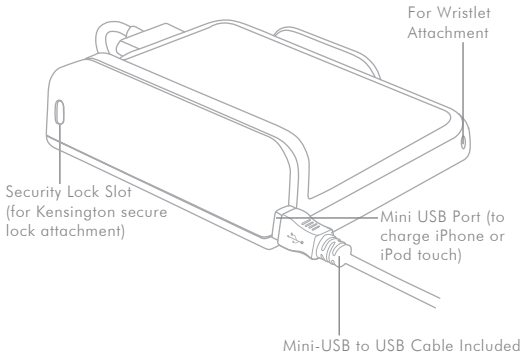

## Using the Swipe It Reader

1. Expand the adjustable spring arm to accommodate your iPhone or iPod touch

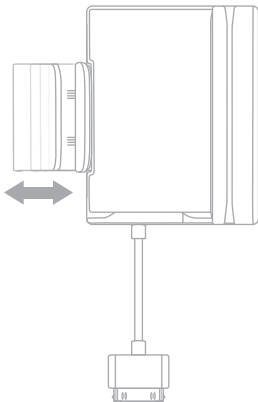

## Using the Swipe It Reader

2. Place your iPhone or iPod touch onto the Swipe It Reader.

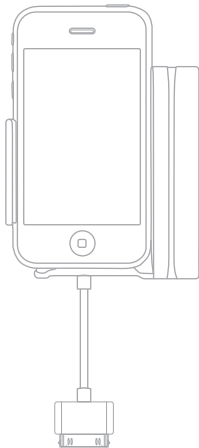

## Using the Swipe It Reader

3. Connect the 30-pin Cable to your iPhone or iPod touch.

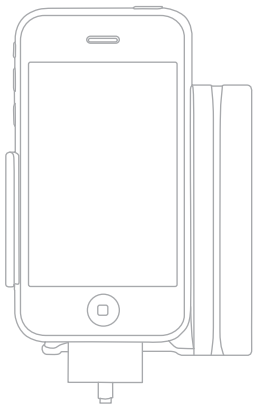



## Using the Swipe It Reader

4. As a mobile credit card terminal, the Swipe It Reader is completely powered by the iPhone. To charge your iPhone or iPod touch, simply connect the included Mini-USB cable to the included USB AC Charger or other USB power source such as computer, battery pack and car charger.

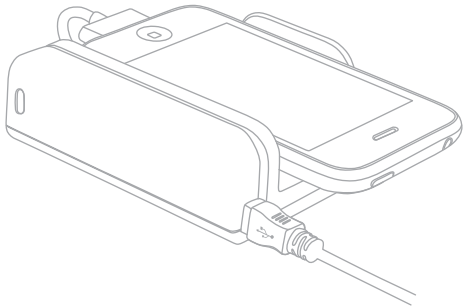

## Merchant Account/Payment Gateway

In order to process the credit card transactions from your iPhone or iPod touch, you must have a merchant account and a Simply EPay payment gateway ready.

If you already have a merchant account, you can continue to use the account with the Swipe It. If you don't have a merchant account, we recommend using one of Simply Swipe It's partners.

Please visit [www.simplyswipeit.com](http://www.simplyswipeit.com) with your computer, it will guide you through step-by-step to set up a Merchant and a Gateway account. Please make sure you obtain and save the Merchant name, Gateway source key, and PIN for usage in configuring the "Simply EPay" gateway settings.

# Installing the Swipe It App

1. Make sure iPhone or iPod touch has an Internet connection. When plugged into the Swipe It Reader first time, iPhone or iPod touch will pop up a screen to indicate "Application Not Installed". Press "Yes" and follow the on-screen instruction to install the Swipe It App. Or without using the Swipe It Reader, in iPhone or iPod touch you can search "Swipe It" or "Macally Peripherals" in App Store to find the Swipe It, then download it to install the app.

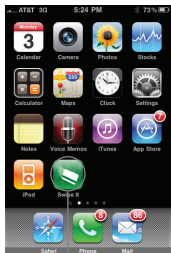

Swipe It App

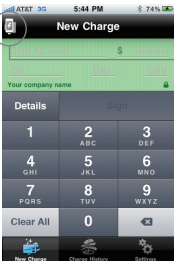

Reader icon

2. Launch the Swipe It app in iPhone or iPod touch, a "Reader" icon should appear on the upper left corner of the app screen. The "Reader" icon indicates that the Swipe It Reader is securely connected to your iPhone or iPod touch. If the icon does not appear on your screen, please reconnect the Swipe It Reader to your iPhone or iPod touch.

## Payment Gateway & General

3. In the Swipe It App, select “Settings”, under Simply EPay enter your merchant name, Source Key and the PIN you obtained earlier.

In “General”, please turn on the corresponding options you choose to use; press “New Charge” at the bottom left corner to return to app home screen.



## Processing the Credit Card

4. Swipe the credit card as shown in the below illustration.

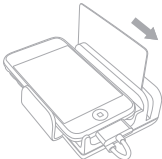

## Processing the Credit Card

5. The credit card number and card expiration date should appear on the screen.

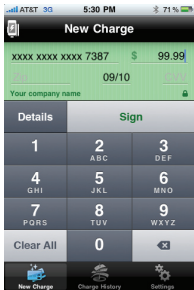
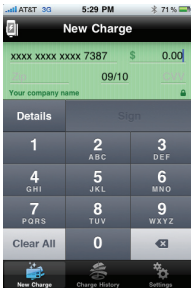

6. Use the on-screen number pad to enter the amount of money you wish to charge.

## Processing the Credit Card

7. Select the “Details” button on the screen, and verify the cardholder’s name. You may then enter the customer’s email address under “Billing” to send them the receipt via email. You may also enter customer’s address and contact info...etc.

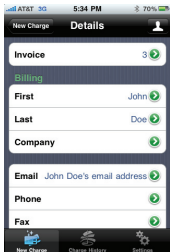

8. Press the “Details” button on the upper left corner to return to the “Details” screen. Press the “New Charge” button to return to the charge screen. Then, press the “Sign” button for the “Signature” screen.

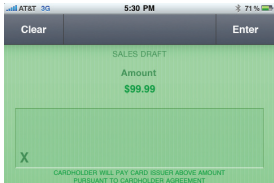

## Processing the Credit Card

9. Ask the cardholder to sign their signature on the screen, and press the “Enter” button to proceed.

10. When the “Charge” button appears in green, press “Charge” to start the transaction.

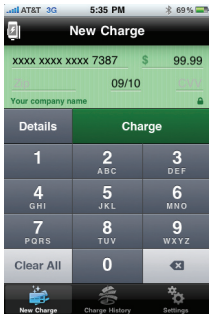

## Processing the Credit Card

11. At the end of the transaction, the “Approved” window will pop up on the display, press “OK”.

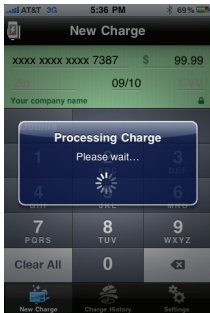
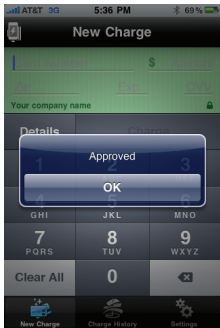



## Refunding a Transaction

12. To refund a charge, press the “Charge History” button and select the transaction you wish to refund.

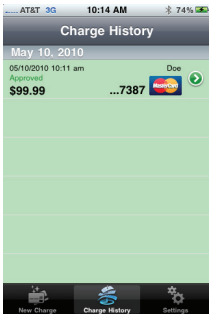
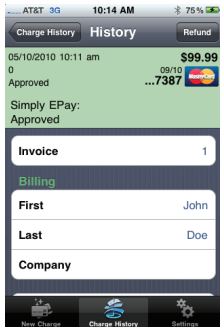

13. Press the “Refund” button on the upper right corner to proceed. Follow the on-screen instruction to complete the refund process.